

Photometric Data

TLP-X-3015N-66 66W 4000k

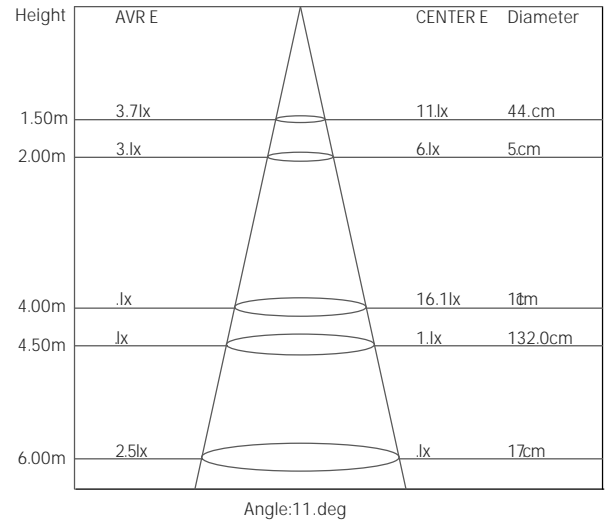

Packing Information

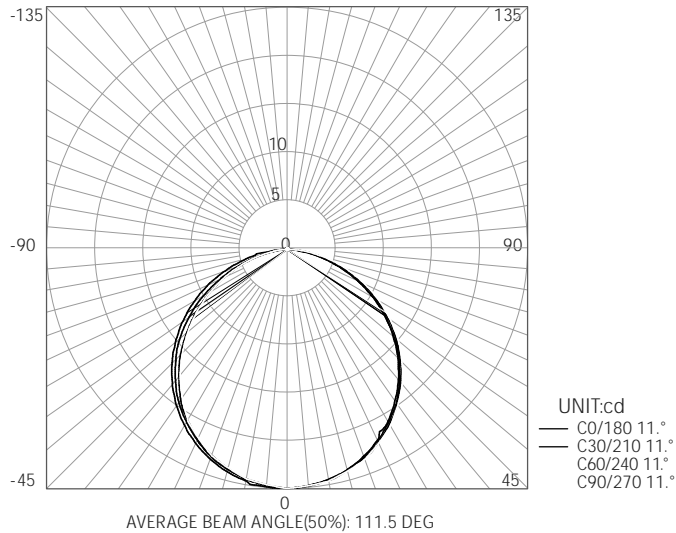
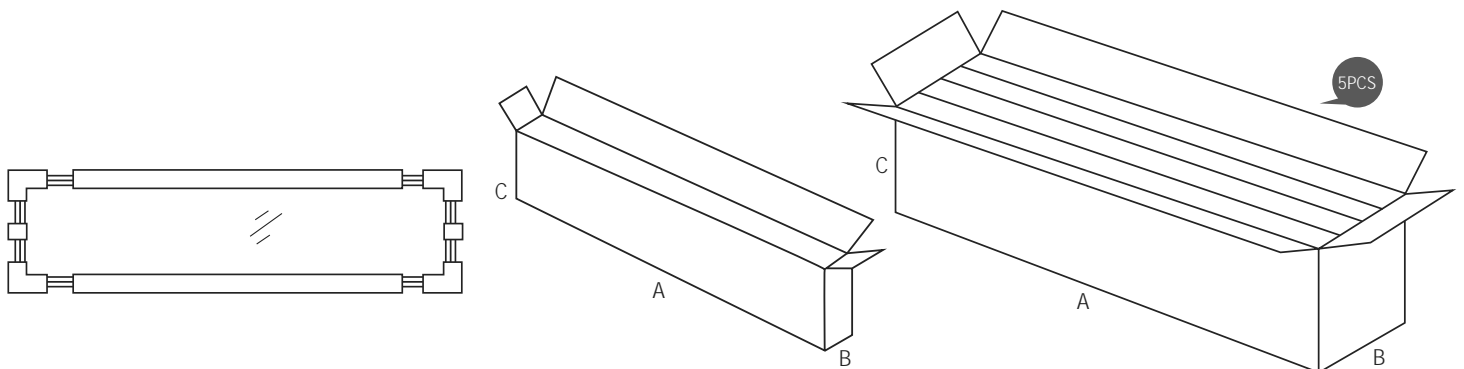

Panel	Box		Carton	
Model No.	ABC MAX (mm)	GW (kg)	ABC MAX (mm)	GW (kg)
TLP-X-3015	1590*35*340	4.9	1620*200*360	26.5