

85 lm/W 296 X 596

Features & Benefits

- *85 lm/W high lumen efficacy, with high 80+ CRI.
- TUV CB, GS, EMC and RoHS certified.
- LM80 20x35mil 2835 SMD, 97.1% lumen maintenance @ 6,000 hours.
- 3T ENTIRE PS PMMA LGP, with extrusion process; 1.2T CHIMEI PS diffuser and DXC light reflector.
- ElecCoat™ technology provides white appearance, with superb heat dissipation performance.
- NanoGap™ technology ensures the high lumen efficacy and protection of the LEDs.
- Control: DALI / 0-10V / TRIAC dim control solutions available.
- Long life: L70 @ 80,000 hours.
- 5 years warranty.

* TLP-F-3060N-18

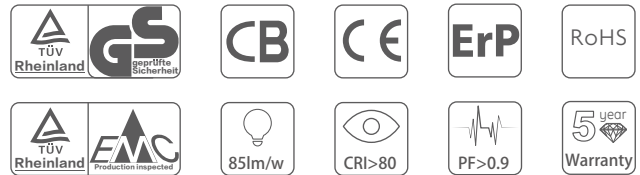

Dimension

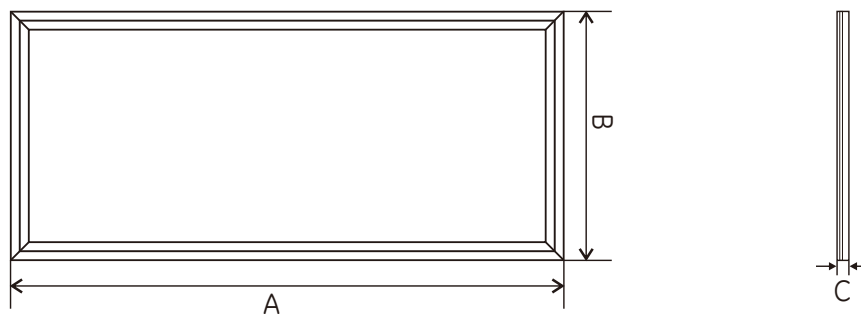

Model	Dimension (mm)		
	A	B	C
TLP-F-3060	296	596	11

Ordering Information

Example: TLP-F-3060N-18

Model	Size	Color Temp		Wattage	
		W	N	18	40
TLP-F	3060 296*596	3000K		18	18W
		4000K		40	40W
		6000K			

Specifications

Optical Parameters

	TLP-F-3060-18			TLP-F-3060-40		
Size	296x596x11					
CCT	6000K	4000K	3000K	6000K	4000K	3000K
Lumen Output (lm) ±5%	1530	1530	1377	3200	3200	2880
LM Efficacy (lm/W) ±5%	85	85	76.5	80	80	72
LED Type / Quantity	20x35mil chip / 108pcs					
CRI / SDCM	>80 / <6					

Electrical Parameters

Rated Power ±5%	18W	40W
Rated / Actual Input	180-260VAC / 100-240VAC 50/60Hz	
Driver Output Data	25-38VDC / 450mA / 16W	25-38VDC / 1030mA / 36W
Power Factor / THD / PE	>0.9 / <20 / 88%	
Driver / Connection	Removable Driver / PIP	
Over Load / Short Circuit	Protection	
Surge / Protection Class IEC	>1KV / Class II	
Hi-pot Test Range	SELV Isolated Driver, 3750VDC / 5mA / 60s	

Life

Warranty	5 years
L70 Lifetime	80,000 hours
LM80	>97.1% lumen maintenance @ 6,000 hours

Others

Dim Control	DALI / 0-10V / TRIAC
Frame Color RAL	Pure white / RAL9016
IP / IK / Glow-wire	IP20 / IK06 / 650 °C
Temperature / Humidity	Working: -20 °C ~40 °C Storage: <60 °C / <75%

Photometric Data

TLP-F-3060N-18 18W 4000k

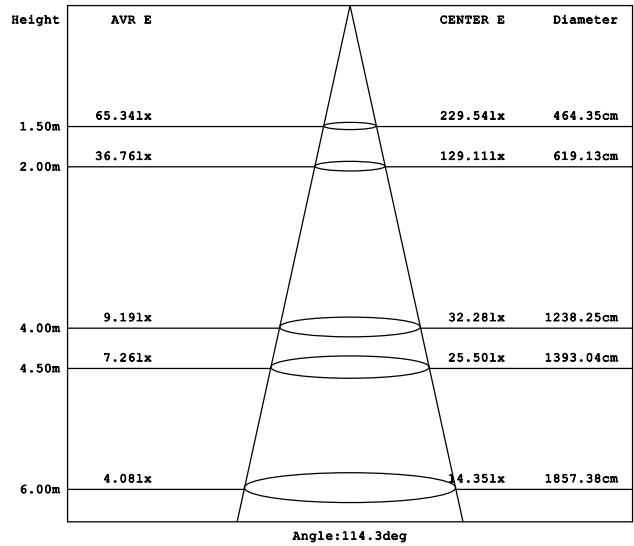
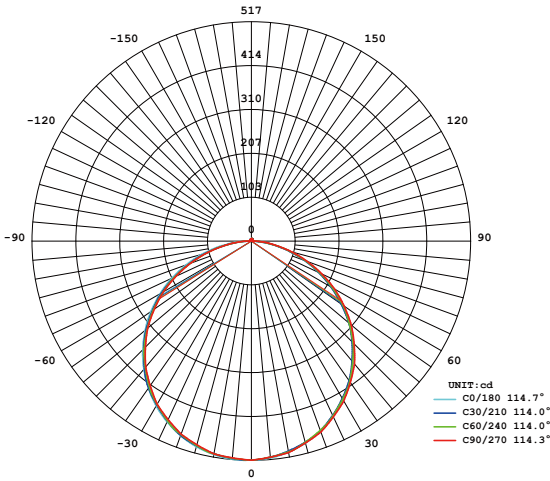

TLP-F-3060W-18 18W 3000k

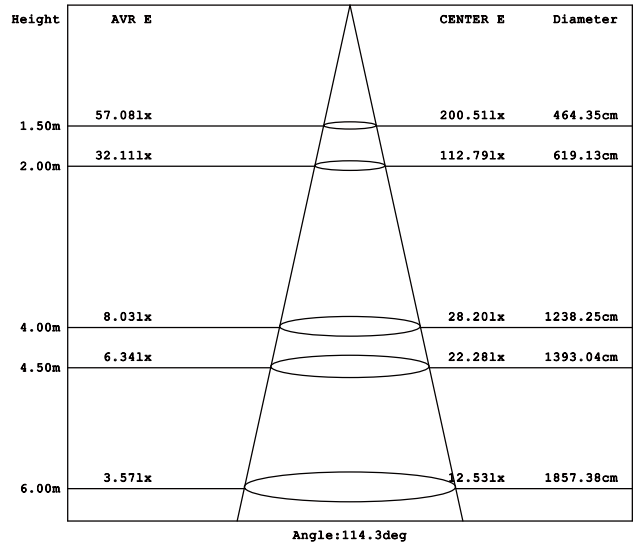
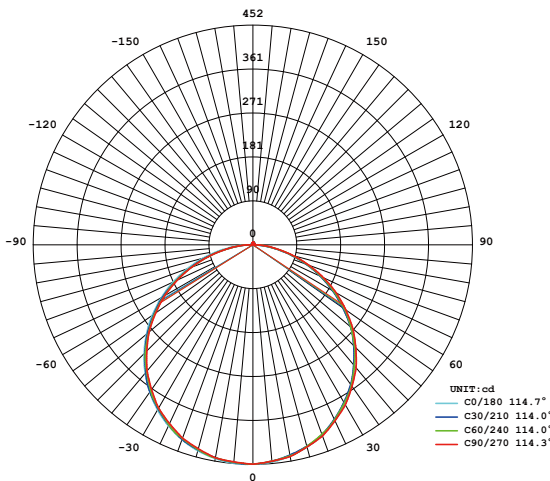

TLP-F-3060N-40 40W 4000k

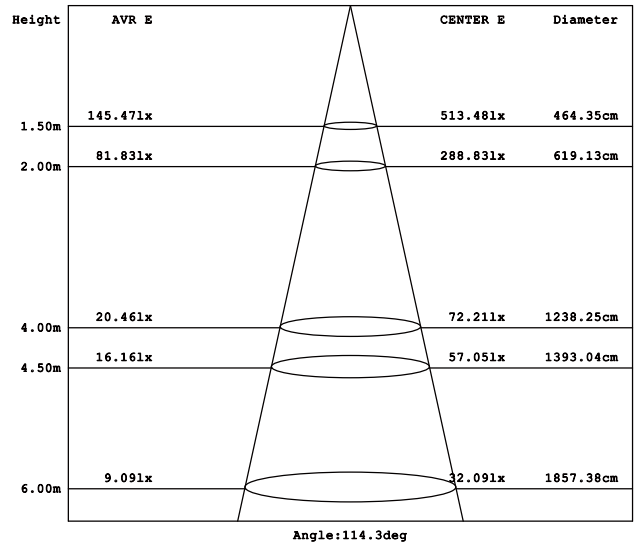
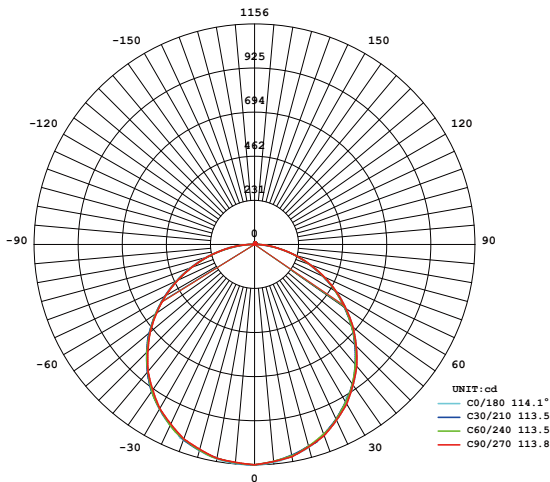

TLP-F-3060W-40 40W 3000k

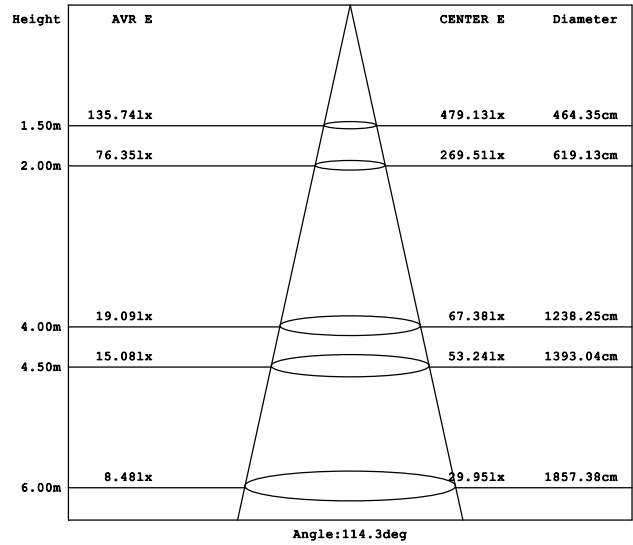
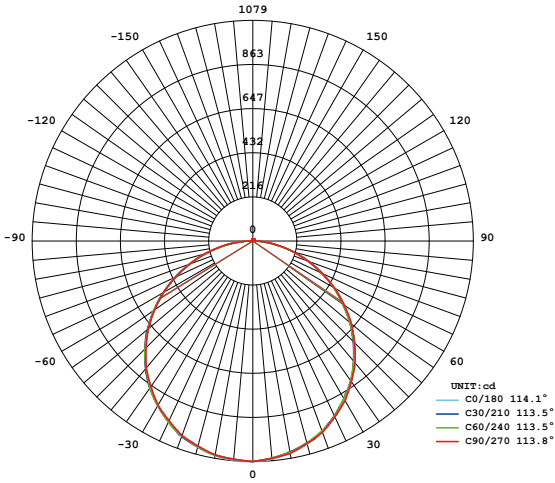

Packing Information

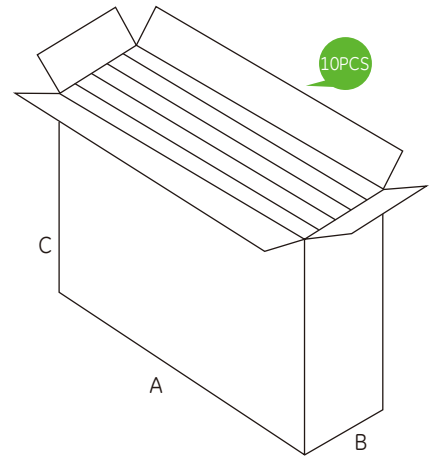
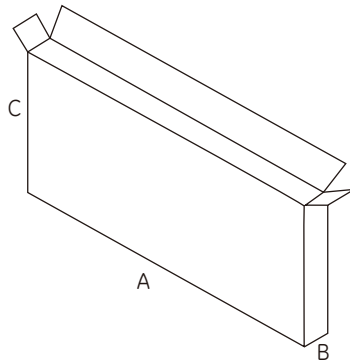

Panel	Box		Carton	
Model No.	ABC MAX (mm)	GW (kg)	ABC MAX (mm)	GW (kg)
TLP-F-3060	660*35*320	2.25	680*200*680	21.95